

MICROMINIATURE COAXIAL CONNECTORS
for 2 mm metric system

Coaxipack 2



ISO 9001 APPROVED



INNOVATIVE TECHNOLOGIES : surface-mount / press-fit / low intermodulation / quick lock / pressure contact

► **ULTRAMINIATURE**

IMP : 50 Ω ,SMT series, press-on electrical contact

UMP : 50 Ω ,SMT series, press-on electrical contact

► **MICROMINIATURE**

SBMO : 50 Ω ,snap-on blind mate series (DC-40GHz)

MMS/MC card/MMT : 50 Ω ,snap-on, SMT series

RF switch

COAXIPACK : metric system 2mm & DIN 41626

SSMA : 50 Ω , screw-on

SSMB : 50 Ω , snap-on

SBMA : 50 Ω , blind mate

Custom models can be developed according to your specifications



Custom packaging can be adapted to the exact customer needs

► **STANDARD**

DT-F : 75 Ω , screw-on

BNC : 50 & 75 Ω , bayonet system, standard & commercial

TNC/TNC 18 : 50 & 75 Ω , screw-on, standard & commercial

DIN 1.6/5.6 : 75 Ω , screw-on, snap-on & slide-on

N/N 18 : 50 & 75 Ω , screw-on, standard & commercial, low intermodulation models, slide-on models

DIN 7/16 : 50 Ω , screw-on, low intermodulation

Other series : HN - UHF - C - LC

► **SPECIAL & HIGH VOLTAGE**

miniQUICK : 50 & 75 Ω , push-pull system, slide-on models

BNC TRX / N TRX : triax series

BNC HT/SHV : bayonet system, 10 KV-10 A

miniQUICK HT : push-pull system, 12 KV-10 A

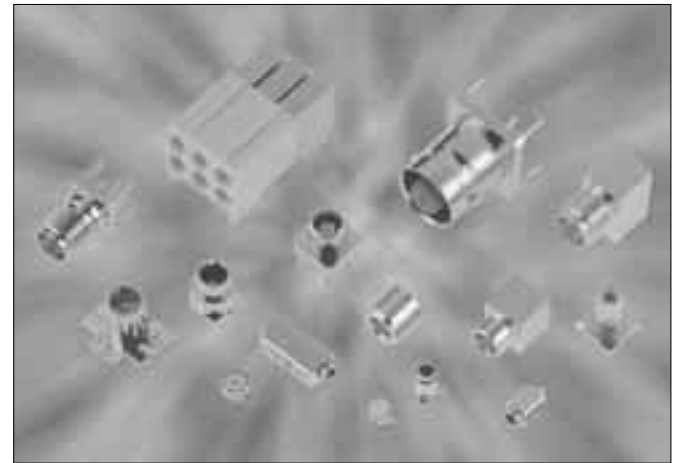
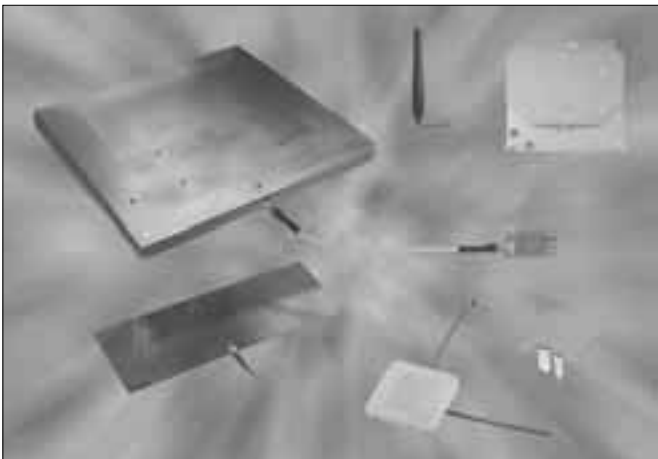

► **MINIATURE**

MCX : 50 & 75 Ω , snap-on

SMA : 50 Ω , screw-on, slide-on, standard & commercial

QMA : 50 Ω , snap-on, quick lock family

SMA 2.9 : 50 Ω , screw-on (DC-40GHz)

SMB, SMB LOCK, SMB CARLOCK : 50 Ω , snap-on

SMC : 50 Ω , screw-on

SMZ : 75 Ω , snap-on, lock-on, type BT43 series

BMA : 50 Ω , blind mate, standard & commercial

DIN 1.0/2.3 : 50 & 75 Ω , screw-on, snap-on & slide-on, lock-on models

FME : easy-connect cabling system

► **BETWEEN-SERIES ADAPTORS**

More than 95 combinations of different interfaces 50 & 75 Ω , push-on type

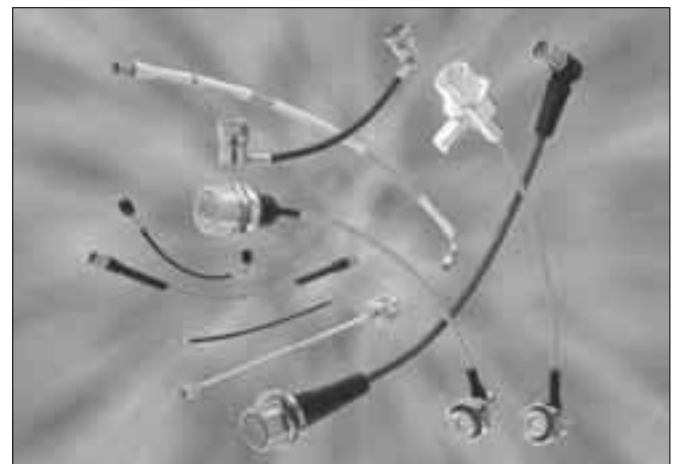

► **COAXIAL CABLE & CABLE ASSEMBLIES**

RG cable ass. : standard & special cables DC-18GHz

Option to RG cable ass. : halogen free, flame retardant

SHF cable ass. : ultra low loss flexible cables DC-40GHz

Corrugated cable assemblies : (IMP : -125 dBm)

Semi-rigid and conformable cables : DC-46GHz

Custom design products (harness)

► **ANTENNAS**

Omnidirectional wire patch antenna

Patch array antenna (new dielectric material)

Patch ceramic or metallic antenna

Printed or wire dipole antenna

Dual polarization antenna

Dual band antenna

Embedded or external antenna

► **ACCESSORIES & ASSEMBLY TOOLING**

	Page
RADIALL company profile	4-5
Introduction	6-7
General	8-9
Applications summary	10
Characteristics	11
Finder guide	12-13
50 Ω connectors	14
Kits for cable-assemblies	19
75 Ω connectors	27
Guide pins	30
Tooling	31-32
Recommended PCB layout	33-34
Procedure and tooling for assembly and disassembly	35
Assembling	36 to 38
Mounting and extraction procedures	39 to 41
Dimensions of applicable cables	42
Index of P/N	42-43



Head Office - Rosny sous Bois

Since 1952, **RADIALL** has specialized in the field of coaxial connectors and cables assemblies. **RADIALL's** experience and high technology focus, combined with our large worldwide production capability have made the company a major supplier of RF coaxial connectors in the world and the number one in Europe.

RESEARCH & DEVELOPMENT

The ever increasing sophistication of microwave communication systems is continually requiring components to meet a higher level of performance. **RADIALL's** research and development groups understand these needs and are committed to searching for product solutions that will be needed in the future. They also are providing continued improvements to our already extensive lines of high performance products. All our engineer teams are equipped with state of the art equipment and facilities, in an effort to provide the best solutions to our customers.



CAD workstation



Screw-machining shop

MANUFACTURING

RADIALL knows that the quality of the connectors components is directly related to the mechanical precision of the machining process, along with good quality procedures. In an effort to continually meet the highest quality standards, all our production plants are equipped with the latest state of the art production equipment. **RADIALL's** manufacturing process maintains strict control of all procedures and incorporates all tooling, machining, surface treatment and assembly operations into the manufacturing process of each production group.



Base station of cellular network

HIGH RELIABILITY

Reliability of inter-connection systems is of the utmost importance in telecommunications applications. This industry need has led **RADIALL** to link high performance design, manufacturing and quality control. This has given the company the capability to produce connectors that will operate in the most stringent environments. The wide range of our product offering allows us to propose the best complete solution for your exact need.



Microwave test device

QUALITY ASSURANCE

RADIALL, as a TQM company, continually searches for improvements to the quality process. We operate a Quality Assurance Program that has been developed in accordance with the national and **CECC** agencies (equivalent to **MIL-I-45208** and **MIL-C-45662** standards). This program has enabled us to achieve QPL approval on several of our connector series. **RADIALL's** Quality Assurance Program operates at all levels of manufacturing from the initial raw incoming material to the final testing procedures just prior to shipping. All test equipment is part of the quality process and is continually inspected on a regular scheduled basis. All production plants in Europe are **AQA P4-NATO** certified.



ISO 9001 ACCREDITATION

This certificate is witness to **RADIALL's** achievement and commitment to the Total Quality Process. **RADIALL** has always been, since its inception, a company committed to being a Total Quality supplier. Quality is our way of life at **RADIALL**.

MAIN FEATURES

Mini coaxial connectors combine the high performance of coaxial connectors with the convenience, compactness and cost effectiveness of 2 mm metric system.

■ COAX

- **Excellent electrical performances**

- Low crosstalk
- Low signal distortion
- High levels of EMI/RFI shielding
- Optimum impedance control

- **Optimized high-speed performance**

- Minimum reflection and propagation delay
- Sub-nanosecond rise time capabilities

- **High reliability** in a wide variety of environments

- Industrial atmosphere, humidity, shock resistance, vibrations ...

■ MINIATURIZED

- **Space saving on PCB**

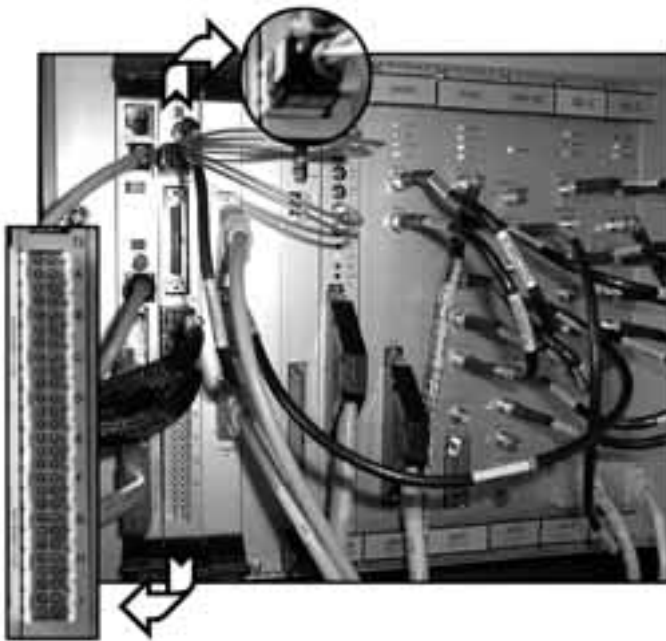

■ METRIC

- **Ideal for high density applications**, e.g. backplane applications

- The chosen hard metric pitch of 2 mm offers space saving on PCB area compared to traditional 2.54 mm pitch.

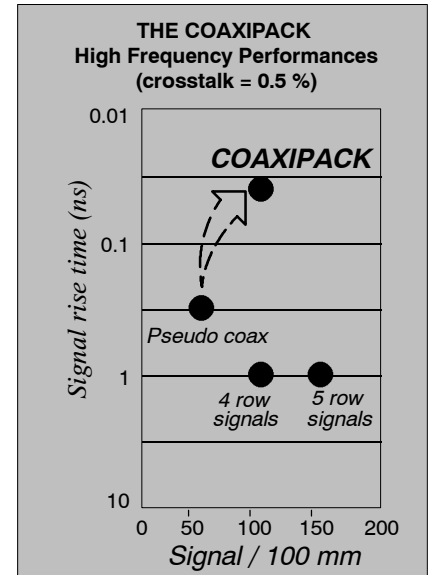

Example of customer application

New generation of NMR spectrometer.
High density connectors permit to dramatically decrease the size of the rack : divided by two compared to the former generation.

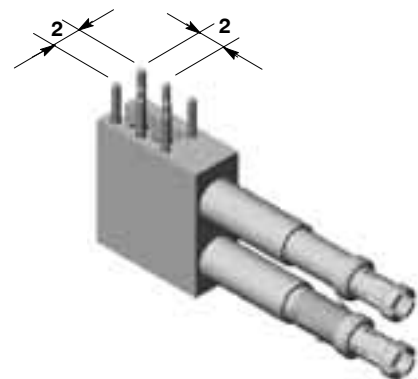

■ MODULAR

- **Stackable with other 2 mm metric modules (e.g. power, signal) from most manufacturers**
- **Maximum flexibility in system architecture**

Thanks to this modular design, system designers are able to upgrade designs and add new functions without having to adopt major changes in hardware and hard metric packaging practice.

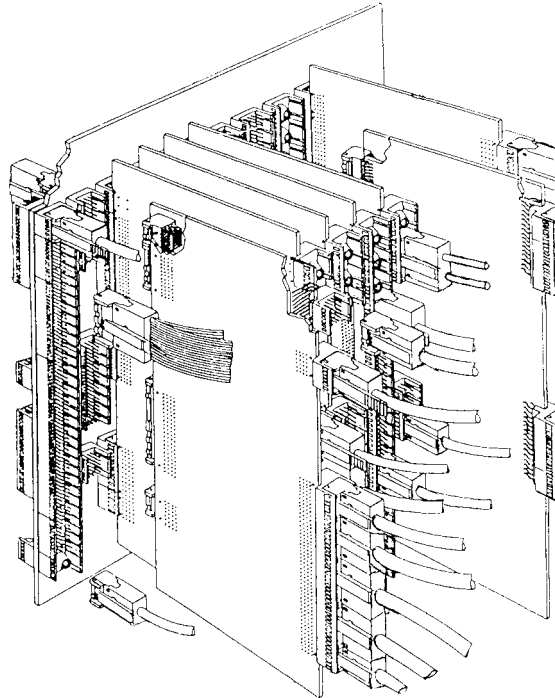

- **Modules can be aligned on PCB without any loss of position**
- **Separation of coaxial, signal and power lines**
- **Cost efficient**

RF functions are separated in specific modules, so that you don't pay for functions you don't need. The modular concept allows specific designs while using standard components.

- Comply with the standard IEC 61076-4-104.



- **COAXIPACK 2 series** provides the highest density of coaxial connectors : each module offers up to 6 coaxial contacts).

- Coaxipack 2 connectors exist with 50Ω or 75Ω interface.

CHARACTERISTICS

- Each connector is composed of a plastic **housing** enclosing coaxial **inserts**.
- The combination of one plastic housing filled with one (or more) inserts is called a **module**.

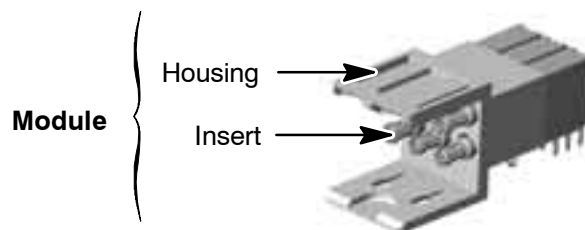

- Depending on the part number, one insert provides one or two **coaxial contacts**.



1 insert = 1 contact

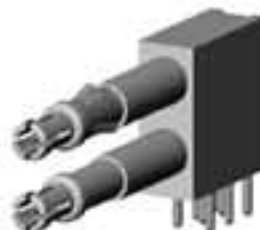

1 insert = 2 contacts

ORDERING OPTIONS

You have the choice to order :

- either a selection of **pre-assembled** modules and cable kits for standard configurations.
- or a wide range of **housings** and **inserts** in order to build your own configuration.



Captivation of the connectors inside the housing

- Choice between a permanent captivation of the insert in the housing or a removable insert with a special tool.

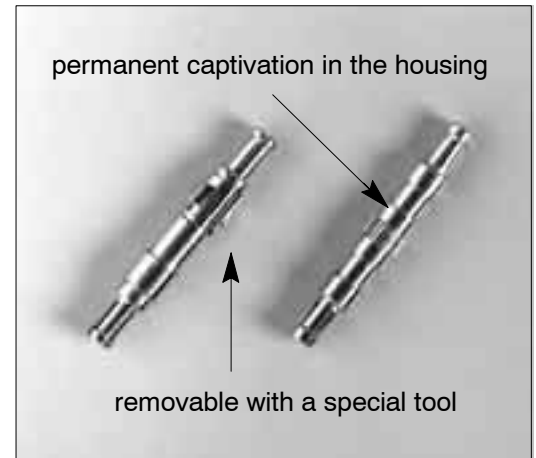

■ Cable kits

It exists two ranges of straight female kits for cable assemblies:

- One **standard kit** which fully complies with the IEC 61076-4-104
- One Radiall's **specific kit** with modified coaxial insert and housing which eases the positioning of the insert inside the housing and **prevents any rotation of the insert** after assembling. Moreover, using these parts numbers, you will **increase the quality level during cable assemblies manufacturing**.

■ Shielded connectors

Two ways can be used to improve the shielding level:

- addition of metal plates to the plastic housing
- metallization of the plastic housing which offers the following advantages:
 - **User friendly**, since there are no separate parts to mount.
 - **No additional space required**



■ Coding system

For improved security in cable-to-board applications, Radiall suggests the use of coding parts which can be inserted in any housing manufactured by Radiall (one male coding part on the male housing and one female coding part on the female housing).

This coding system provides up to **18 coding possibilities**.

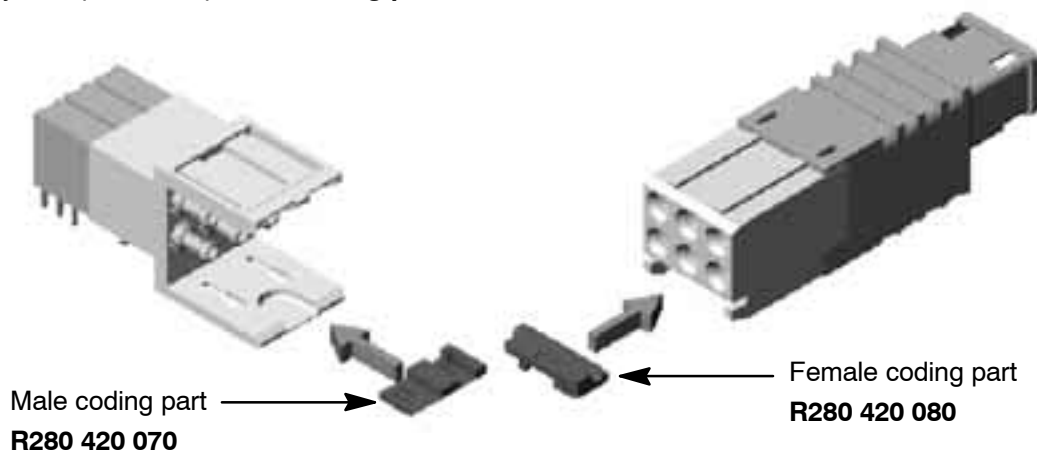

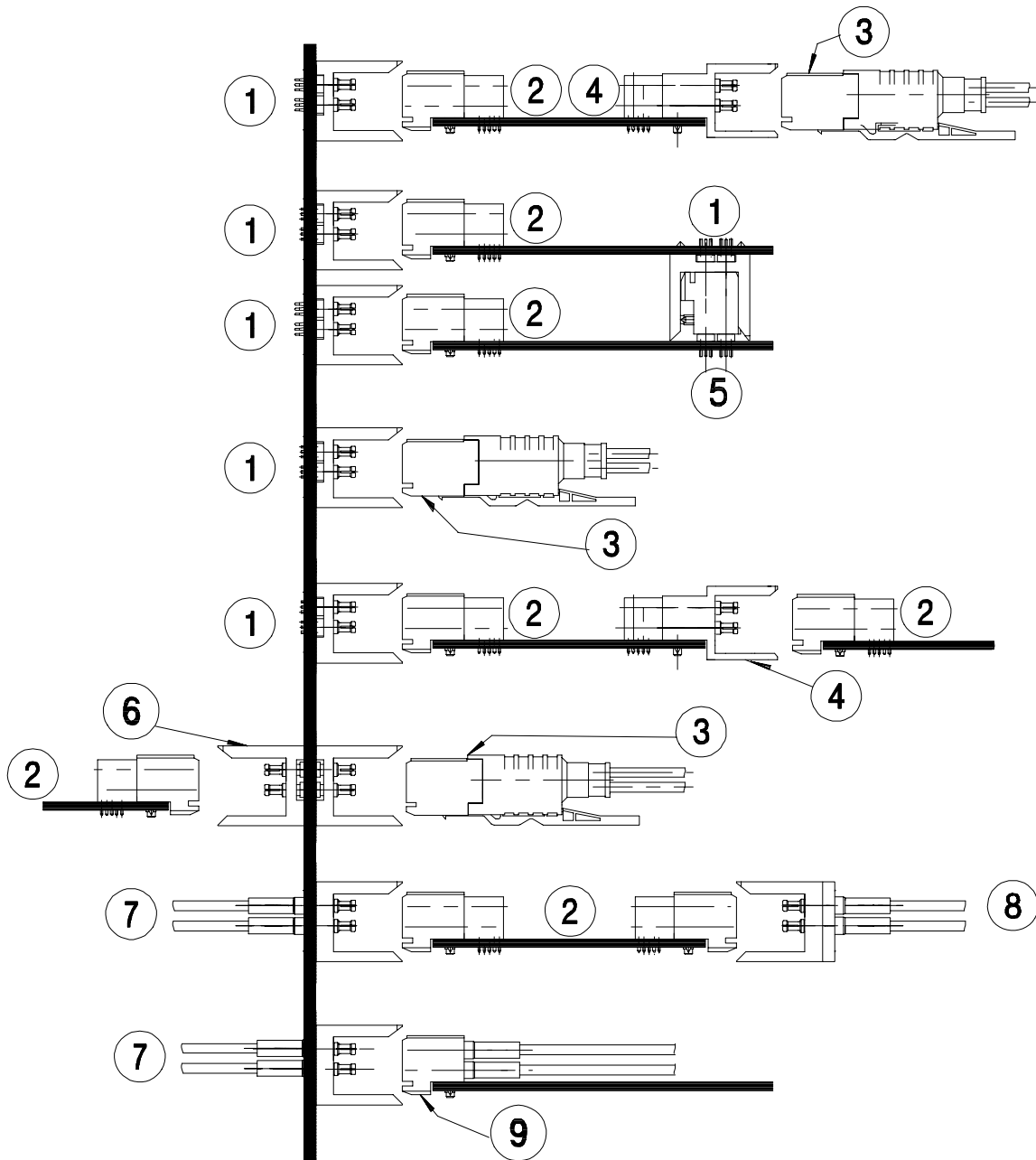

Configurations	Part number	Page
①	R694 251 021 to 027	14
②	R694 252 101 to 107	17
③	R694 252 507 to 537	19
④	R694 251 111 to 117	15
⑤	R694 252 037	not shown, please consult us
⑥	R694 261 906 x 2 + R199 001 733 or R694 261 076 x 2 + R199 001 703 to 713	24 25
⑦	R694 261 906 + R199 001 203 to 223	23
⑧	R694 261 906 + R199 001 203 to 223 + spacer R280 420 400	23 (spacer not shown)
⑨	R694 262 906 + R199 001 003 to 023	21

MICROMINIATURE COAXIAL CONNECTOR SYSTEM FOR BACK PLANE

Electrical

Impedance	50 Ω and 75 Ω	
Frequency range	DC - 6 GHz	
V.S.W.R. <i>mated pair</i>	< 1.15 at 2 GHz (<i>typical value</i>)	
Insertion loss <i>mated pair</i>	0.1 dB at 2 GHz (<i>typical value</i>)	
RF leakage	-37 dB at 2 GHz (<i>typical value</i>)	
Voltage rating	500 V	
Dielectric withstanding voltage	750 V	
Insulation resistance	\geq 5000 M Ω	
Contact resistance	Initial	After environmental test
center contact (m Ω)	3.5	4.2
outer contact (m Ω)	0.45	0.6
Rise time degradation (corrected for board effects) at 300 ps	6 ps	
Difference in propagation delay between shortest and longest line	26 ps	
Near end crosstalk at 300 ps	0.2%	

Mechanical

Mating cycles	500
Engagement and separation force	
engagement	2.5 N
separation	2.2 N
Contact density	2 to 6 contacts per module 60 contacts per 120 mm x 16 mm

Environmental

Temperature range	- 25 / + 125 $^{\circ}$ C
-------------------	---------------------------

















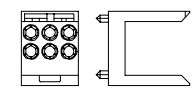
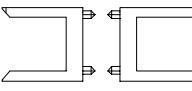
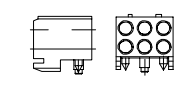
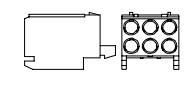



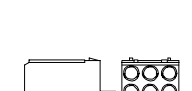

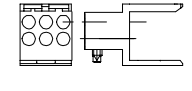
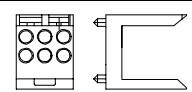
Material

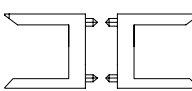
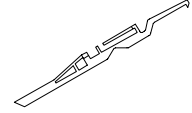



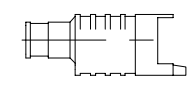

Housing	Liquid Crystal polymer (LCP) glass filled
Mini coax. contacts <i>bodies</i>	Brass or bronze
<i>insulators</i>	PTFE
<i>spring contacts</i>	Beryllium copper

Plating

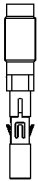
Mini coax contacts	Gold plated for contact zone
--------------------	------------------------------

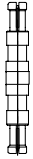
Further information on electrical performances, testing methods and spice modelling are available upon request.

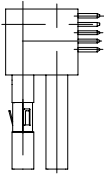
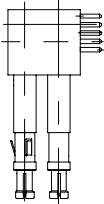
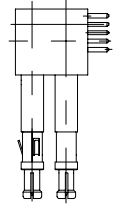
INSERT		R199 001 003 Female/cab 2/50/S removable insert page 21	R199 001 023 Female/cab 2.6/50/S removable insert page 21	R199 001 053 Female/cab 2.5/75/S removable insert page 29	R199 001 203 Male cab 2/50/S removable insert page 23	R199 001 223 Male/cab 2.6/50/S removable insert page 23	R199 031 003 Female/cab 2/50/S removable insert (specific) page 22
HOUSING							
R694 261 076 Male housing page 14							
R694 261 076 2 Male housings page 25							
R694 262 036 Female press-in page 18							
R694 262 056 Female pages 20-28							
R694 362 056 Female for high quality cable- assemblies (specific) page 22							
R694 261 036 Male press-in page 16 R694 261 035 (shielded version) pages 16-27							
R694 261 906 Male housing page 23							
R694 261 906 2 Male housings page 24							
R280 420 030 Latch pages 20-28							
R280 420 010 Cover pages 20-28							

<p>R199 031 023 (specific) Female/cab 2.6/50/S removable insert page 22</p> 																				
<p>R199 002 413 Male PCB solder page 14</p> 	●																			
<p>R199 001 703 Male-male insert page 25</p> 		●																		
<p>R199 001 713 Male-male insert page 25</p> 		●																		
<p>R199 001 733 Male-male removable insert page 24</p> 																				
<p>R199 001 502 R/A female PCB solder removable insert page 18</p> 						●														
<p>R199 001 452 R/A male PCB solder removable insert page 27</p> 										●										
<p>R199 001 402 R/A male PCB solder removable insert page 16</p> 										●										
<p>R280 420 070 Male coding part page 9</p> 	●	●																		
<p>R280 420 080 Female coding part page 9</p> 											●	●								

COAXIPACK 2 50 Ω

STRAIGHT MALE MODULES

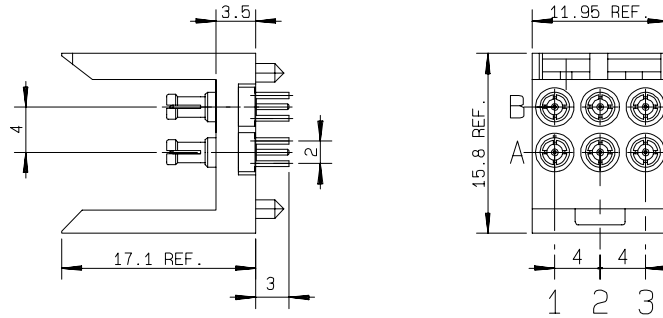

Composed with R694 261 076 + R199 002 413 (PCB 2 mm)

part number	position	number of contacts	recommended PCB thickness (mm)	P.C.B layout
R694 251 021		2	2 max	P01
R694 251 022		2	2 max	P01
R694 251 023		2	2 max	P01
R694 251 024		4	2 max	P01
R694 251 025		4	2 max	P01
R694 251 026		4	2 max	P01
R694 251 027*		6	2 max	P01

STRAIGHT MALE HOUSING

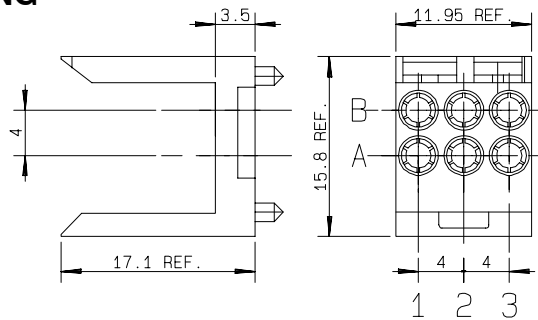

part number	P.C.B layout
R694 261 076	P01

STRAIGHT MALE PCB INSERT, SOLDER TYPE

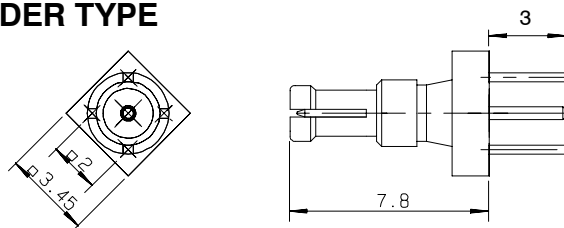

part number	recommended PCB thickness (mm)	P.C.B layout	type
R199 002 413	2	P01	Straight male solder type

* packaging = 30 pieces. For unit packaging, add "W" after the P/N.

RIGHT ANGLE MALE MODULES

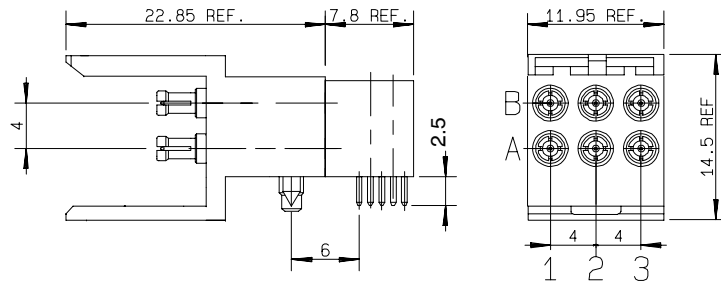
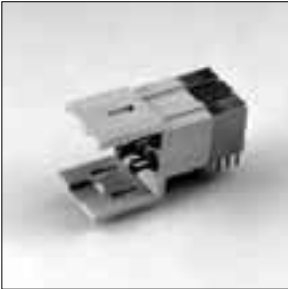

Composed with R694 261 036 + R199 001 402

part number	position	number of contacts	recommended PCB thickness (mm)	P.C.B layout	assembling	extraction
R694 251 111		2	1.6	P03	A02	U01
R694 251 112		2	1.6	P03	A02	U01
R694 251 113		2	1.6	P03	A02	U01
R694 251 114		4	1.6	P03	A02	U01
R694 251 115		4	1.6	P03	A02	U01
R694 251 116		4	1.6	P03	A02	U01
R694 251 117		6	1.6	P03	A02	U01
R694 251 127●		6	1.6	P03	A02	U01

- Upon request. Shielded module composed with R694 261 035 + R199 001 402

COAXIPACK 2 50 Ω

RIGHT ANGLE MALE HOUSING WITH PRESS-IN FIXING STUD

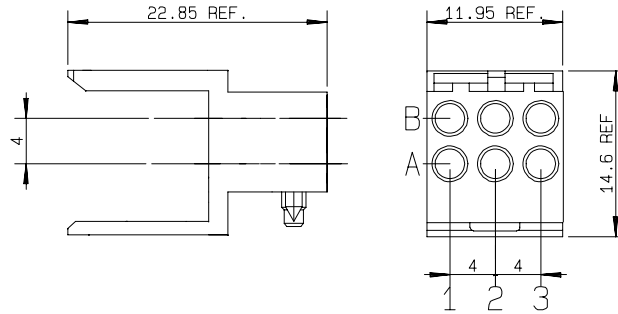

Part number	P.C.B layout
R694 261 035 ⁽¹⁾	P03
R694 261 036	P03

RIGHT ANGLE MALE REMOVABLE PCB INSERT, SOLDER TYPE

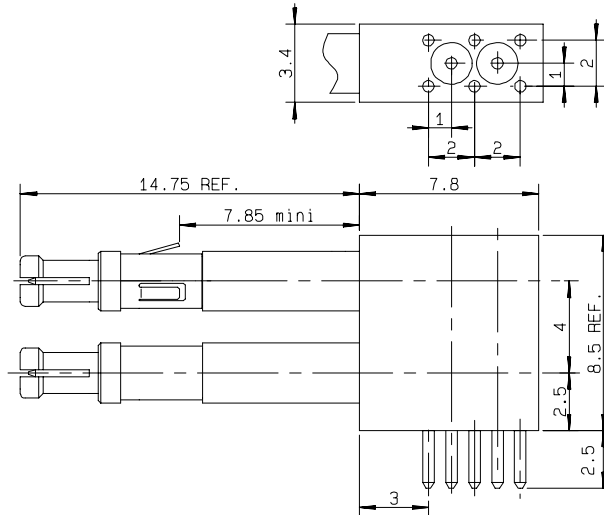

part number	recommended PCB thickness (mm)	P.C.B layout	extraction	type
R199 001 402*	1.6	P03	U01	Right angle male solder type

* packaging = 20 pieces. For unit packaging, add "W" after the P/N.

(1) : shielded version

COAXIPACK 2 50 Ω

RIGHT ANGLE FEMALE MODULES

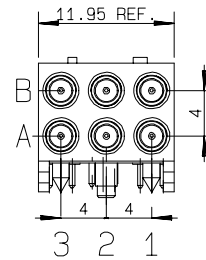
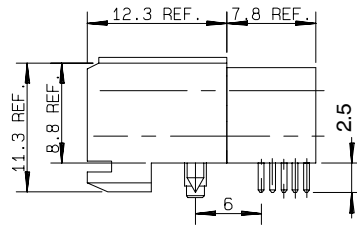

Composed with : R694 262 036 + R199 001 502

part number	position	number of contacts	recommended PCB thickness (mm)	P.C.B layout	assembling
R694 252 101		2	1.6	P03	A01
R694 252 102		2	1.6	P03	A01
R694 252 103		2	1.6	P03	A01
R694 252 104		4	1.6	P03	A01
R694 252 105		4	1.6	P03	A01
R694 252 106		4	1.6	P03	A01
R694 252 107*		6	1.6	P03	A01

* packaging = 30 pieces. For unit packaging, add "W" after the P/N.

COAXIPACK 2 50 Ω

FEMALE HOUSING WITH PRESS-IN FIXING STUD (for right-angle inserts hereunder)

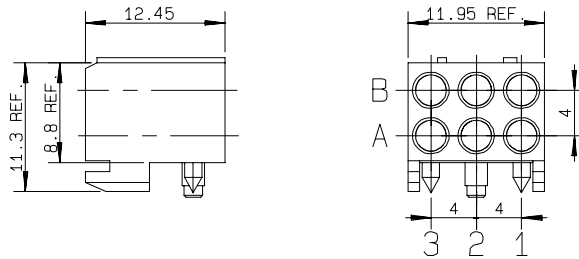
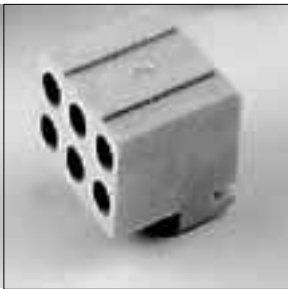

part number	P.C.B layout
R694 262 036	P03

RIGHT ANGLE FEMALE REMOVABLE PCB INSERT, SOLDER TYPE

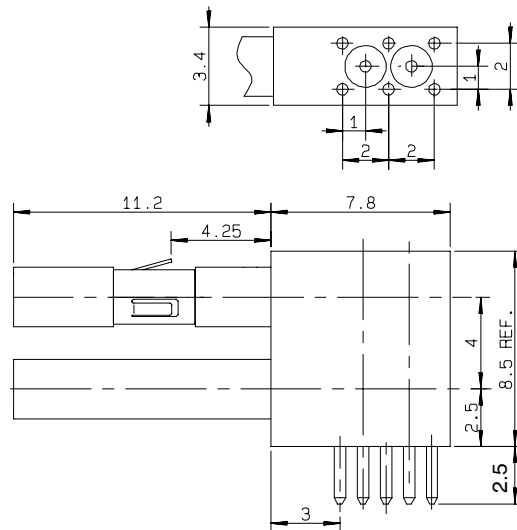
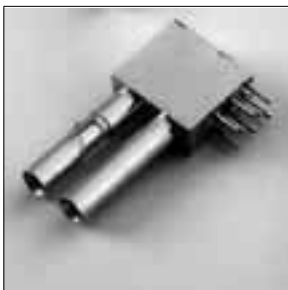

part number	recommended PCB thickness (mm)	P.C.B layout	type
R199 001 502	1.6	P03	Right angle female solder type

Advantages of RADIALL's kits for cable assemblies

- **The specific design of the cover allows:**
 - easy mounting on the cable assembly, even after cabling of the contacts (see assembling A03)
 - easy repair
- **Possibility of fastening the cables to the cover because of two openings in the cover.**

STRAIGHT FEMALE KIT FOR CABLE ASSEMBLIES

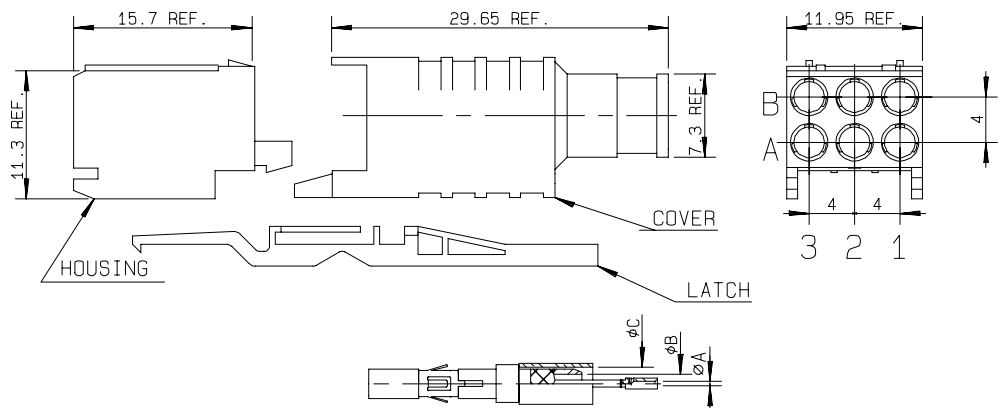
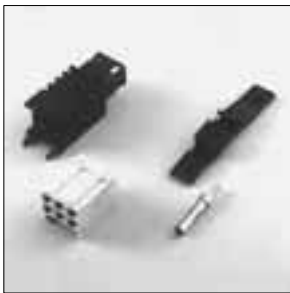

One kit is composed with :

- 1 housing R694 262 056
- 6 coax. inserts R199 001 003 or R199 001 023
- 1 cover R280 420 010
- 1 latch R280 420 030

cable group	part number	position	dimensions (mm)			mounting	assembling	extraction
			A	B	C			
2/50/S	R694 252 507		0.4	1	2.55	M01	A03	U02
2.6/50/S	R694 252 537		0.6	1.7	2.92	M01	A03	U02

COAXIPACK 2 50 Ω

COVER

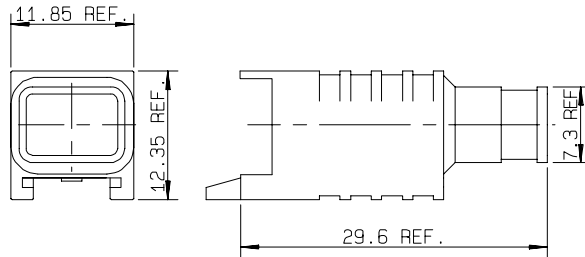
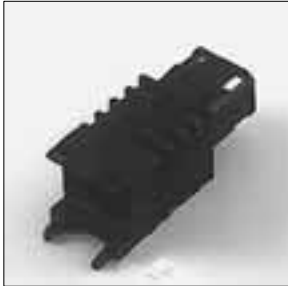

part number
R280 420 010

FEMALE HOUSING FOR REMOVABLE CABLE INSERT

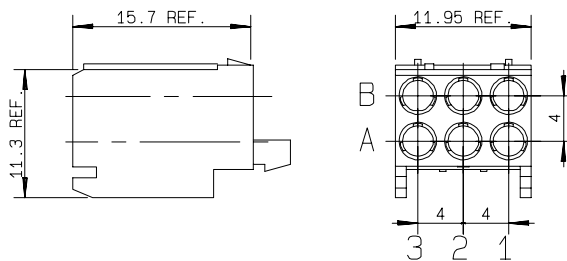

part number
R694 262 056

LATCH



part number
R280 420 030

KIT : Cover + Female housing + Latch

part number	composed with	notes
R280 420 058*	R694 262 056 + R280 420 010 + R280 420 030	Female housing for cable inserts + cover + latch

* packaging = 100 pieces. For unit packaging, add "W" after the P/N.

COAXIPACK 2 50 Ω

STRAIGHT FEMALE REMOVABLE INSERTS, FULL CRIMP TYPE

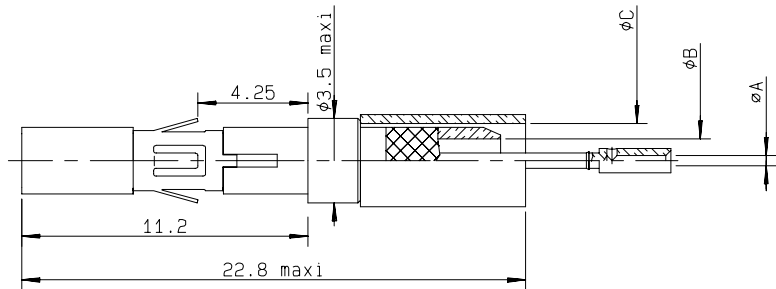
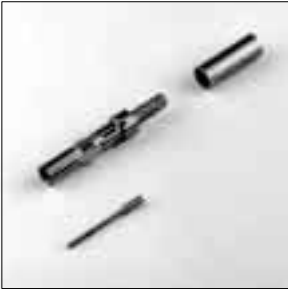

cable group	part number	dimensions (mm)			mounting	extraction
		A	B	C		
2/50/S	R199 001 003	0.4	1	2.55	M01	U02
2.6/50/S	R199 001 023	0.6	1.7	2.92	M01	U02

FEMALE HOUSING WITH PRESS-IN FIXING STUD (for straight inserts hereabove)

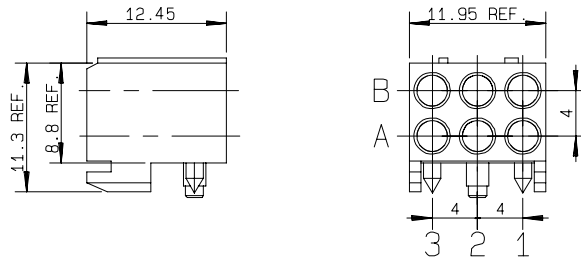
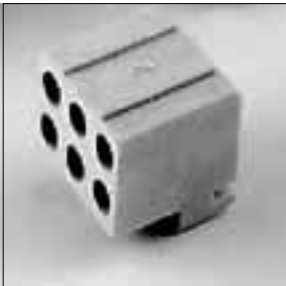

part number	P.C.B layout
R694 262 906	P03

- Upon request.

COAXIPACK 2 50 Ω

SPECIFIC COAXIAL INSERTS AND KITS FOR HIGH QUALITY CABLE ASSEMBLY.

Coaxial inserts and housings have been modified in order to ease the positioning of the insert inside the housing and prevent any rotation of the insert after assembling.

By using these special pieces, quality level and ease of mounting of cable assemblies are improved.

These specific inserts and housing can't be mixed with the standard one's.

STRAIGHT FEMALE REMOVABLE INSERTS, FULL CRIMP TYPE

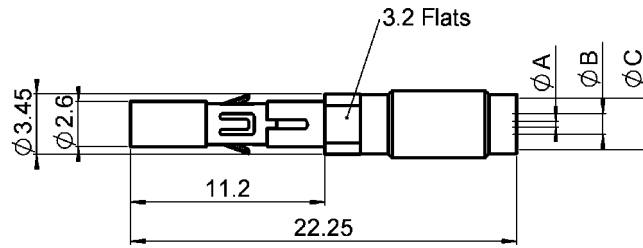

cable group	part number	dimensions (mm)			mounting	extraction
		A	B	C		
2/50/S	R199 031 003*	0.4	1	2.55	M01	U02
2.6/50/S	R199 031 023*	0.6	1.7	2.92	M01	U02

* packaging = 100 pieces. For unit packaging, add "W" after the P/N.

STRAIGHT FEMALE KIT FOR CABLE ASSEMBLIES

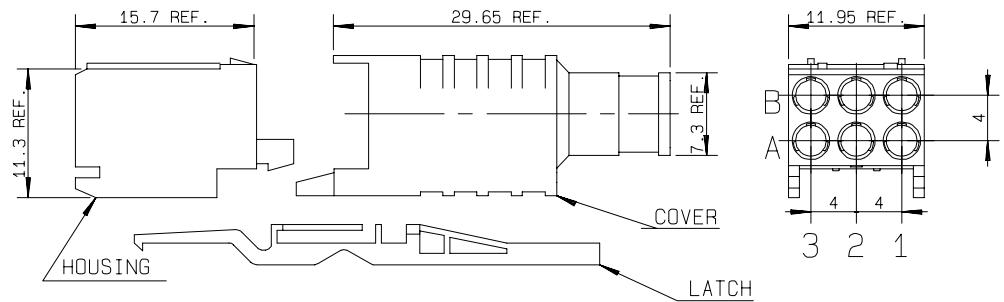
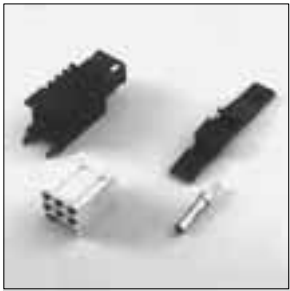

One kit is composed with :

- 1 housing R694 362 056
- 6 coax. inserts R199 031 003 or R199 031 023
- 1 cover R280 420 010
- 1 latch R280 420 030

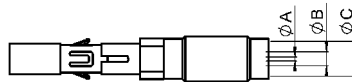

cable group	part number	position	dimensions (mm)			mounting	assembling	extraction
			A	B	C			
2/50/S	R694 352 507**		0.4	1	2.55	M01	A03	U02
2.6/50/S	R694 352 537**		0.6	1.7	2.92	M01	A03	U02

** packaging = 30 pieces. For unit packaging, add "W" after the P/N.

COAXIPACK 2 50 Ω

FEEDTHROUGH MALE JACK

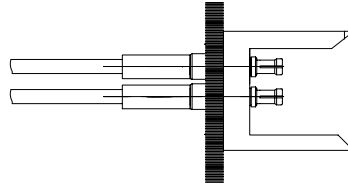

Composed with : R694 261 906 + R199 001 203 or R199 001 223

STRAIGHT MALE HOUSING

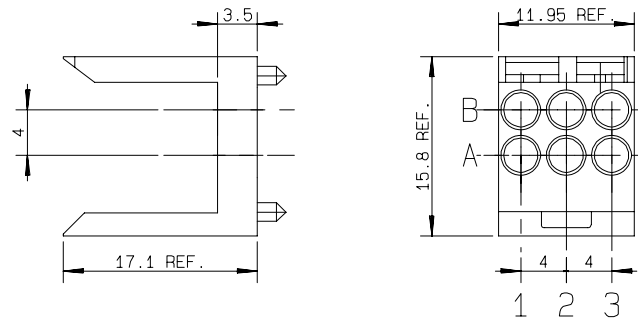

part number	P.C.B layout	notes
R694 261 906	P02	Male wide body & removable coax

STRAIGHT MALE REMOVABLE INSERTS, FULL CRIMP TYPE

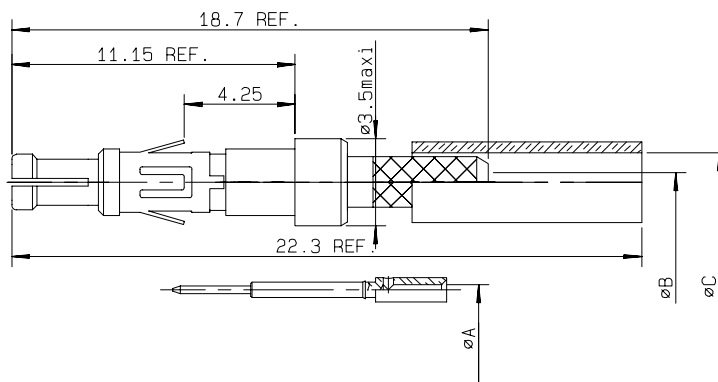
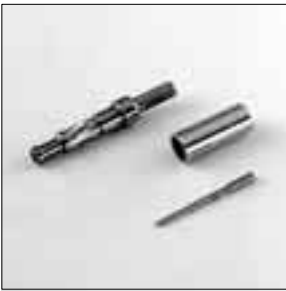

cable group	part number	dimensions (mm)			recommended PCB thickness (mm)	mounting
		A	B	C		
2/50/S	R199 001 203●	0.4	1	2.55	3.2 ± 0.1	M01
2.6/50/S	R199 001 223●	0.6	1.8	2.92	3.2 ± 0.1	M01

● Upon request.

COAXIPACK 2 50 Ω

FEEDTHROUGH MALE MODULE WITH REMOVABLE INSERT

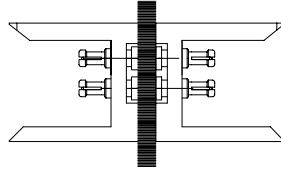

Composed with : R694 261 906 + R199 001 733

STRAIGHT MALE HOUSING

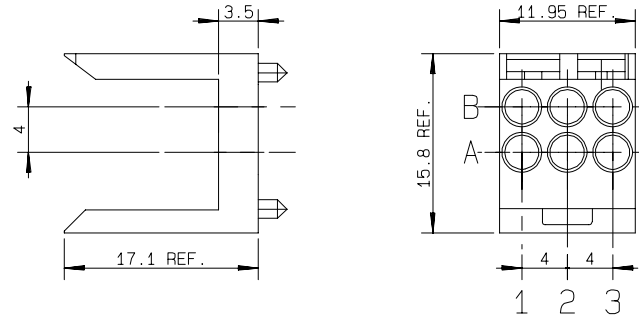

part number	P.C.B layout	notes
R694 261 906	P02	Male wide body & removable coax

MALE-MALE REMOVABLE INSERT

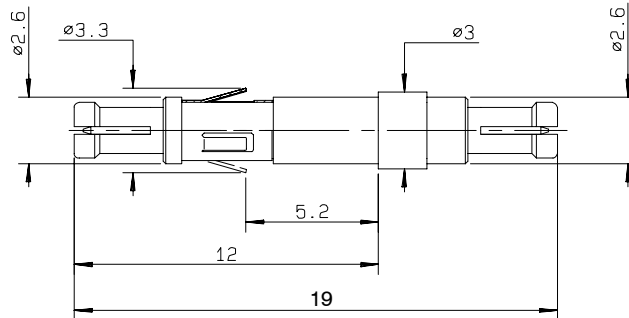

part number	P.C.B layout	panel thickness (mm)	extraction
R199 001 733 (1)	P02	3.2 ± 0.05	U01

(1) To remove the contact, use tool R282 920 010.

COAXIPACK 2 50 Ω

FEEDTHROUGH MALE MODULE WITH NON REMOVABLE INSERT

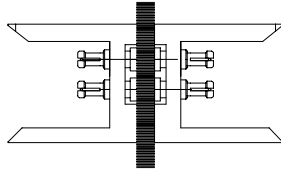

Composed with : R694 261 076 + R199 001 703 or R199 001 713

STRAIGHT MALE HOUSING

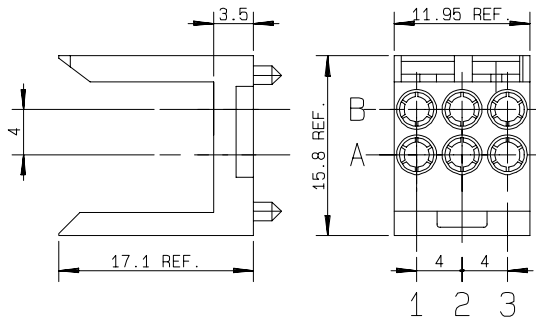

part number	P.C.B layout
R694 261 076	P01

MALE-MALE NON REMOVABLE INSERT

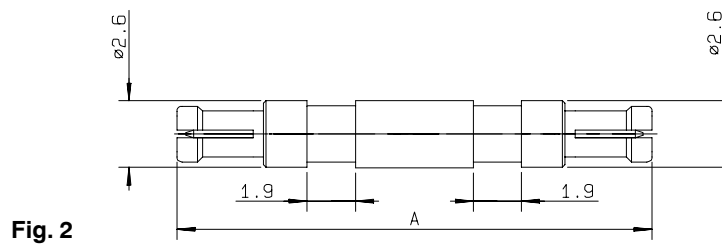
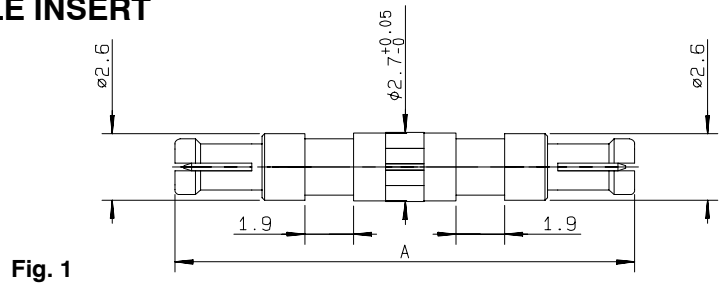

part number	fig.	dimension A (mm) (1)	P.C.B layout	panel thickness (mm)
R199 001 703●	1	18	P02	2 ± 0.1
R199 001 713	2	18.6	P02	2.4 ± 0.2

(1) Other length and P.C.B thickness available upon request. Please consult.

● Upon request.

COAXIPACK 2 50 Ω

DEMONSTRATION BOARD

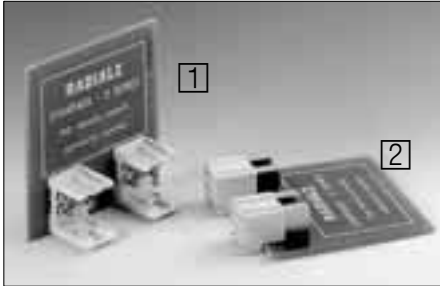

part number	position	designation	N°
R299 400 020		Mother board (with male inserts)	1
R299 400 030		Daughter board (with female inserts)	2

DEMONSTRATION PIGTAIL



part number	position	designation
R284 906 002		20cm pigtail can be used with R299 400 020

STANDARD CABLE ASSEMBLY (equipped with straight female crimp type coaxial inserts)

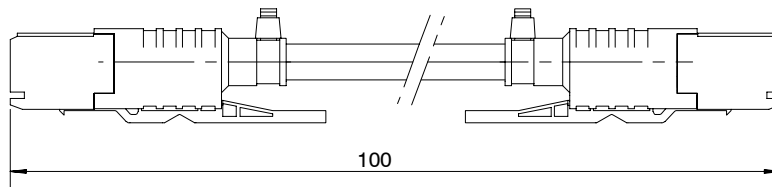

cable group	part number	extraction
2.6/50/S	R285 930 005	U02

QUALIFICATION KIT

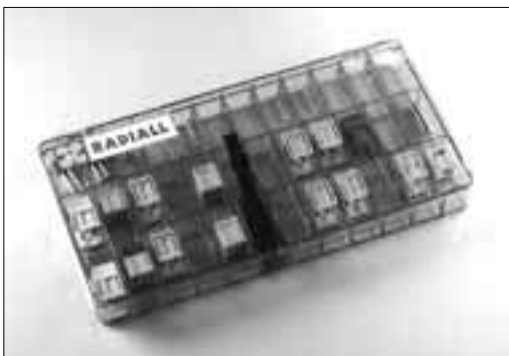

part number
R280 741 010

COAXIPACK 2 75 Ω

RIGHT ANGLE MALE SHIELDED MODULE

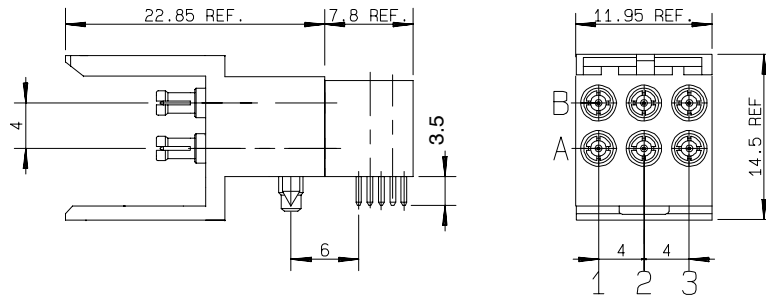
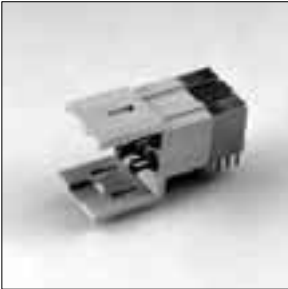

Composed with : R694 261 035 + R199 001 452

part number	position	number of contacts	recommended PCB thickness (mm)	P.C.B layout	assembling
R694 251 137*		6	2.4 max	P03	A02

* packaging = 30 pieces. For unit packaging, add "W" after the P/N.

RIGHT ANGLE MALE HOUSING WITH PRESS-IN FIXING STUD

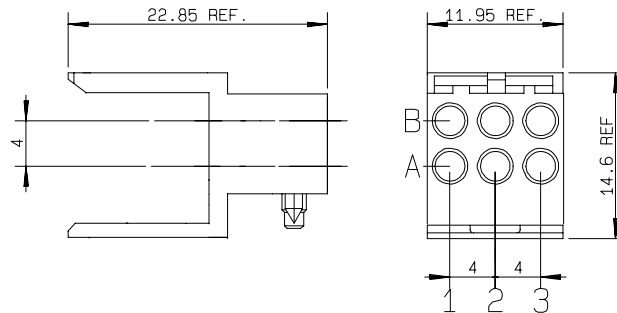

part number	P.C.B. layout
R694 261 035 ⁽¹⁾	P03
R694 261 036	P03

RIGHT ANGLE MALE REMOVABLE PCB INSERT, SOLDER TYPE

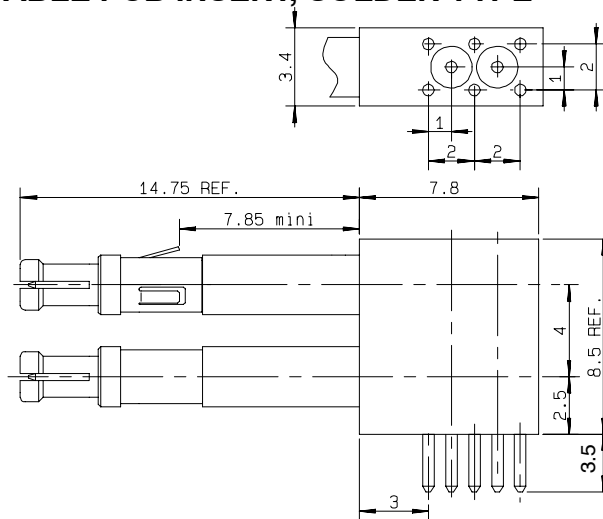

part number	recommended PCB thickness (mm)	P.C.B layout	extraction	notes
R199 001 452**	2.4 max	P03	U01	Right angle male solder type

** packaging = 100 pieces. For unit packaging, add "W" after the P/N.

(1) : shielded version

COAXIPACK 2 75 Ω

STRAIGHT FEMALE SHIELDED KIT

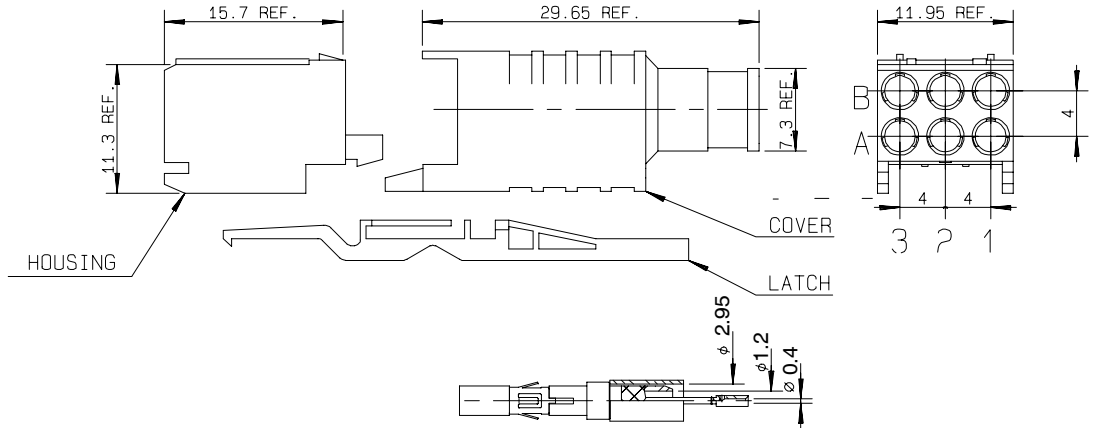
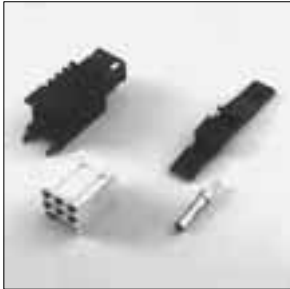

One kit is composed with :

- 1 housing R694 262 056
- 6 coax. inserts R199 001 053
- 1 cover R280 420 010
- 1 latch R280 420 030

cable group	part number	position	mounting	assembling	Extraction
2.5/75/D	R694 252 557*		M01	A03	U02

COVER

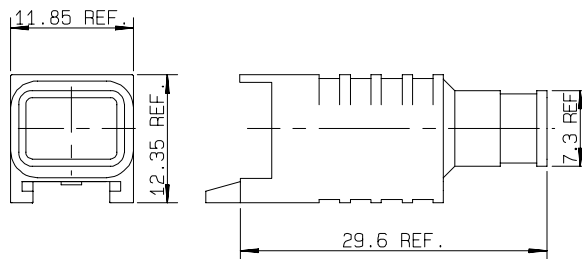

part number
R280 420 010

FEMALE HOUSING FOR REMOVABLE CABLE INSERT

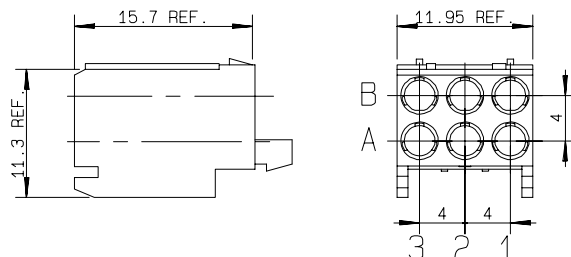

part number
R694 262 056

* packaging = 30 pieces. For unit packaging, add "W" after the P/N.

COAXIPACK 2 75 Ω

LATCH

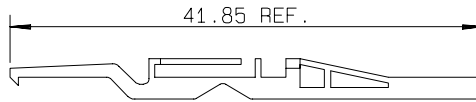

part number
R280 420 030

STRAIGHT FEMALE REMOVABLE INSERT, FULL CRIMP TYPE

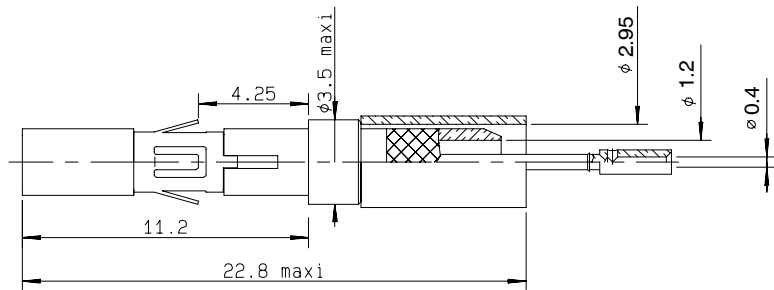

cable group	part number	mounting
2.5/75/D	R199 001 053*	M01

* packaging = 100 pieces. For unit packaging, add "W" after the P/N.

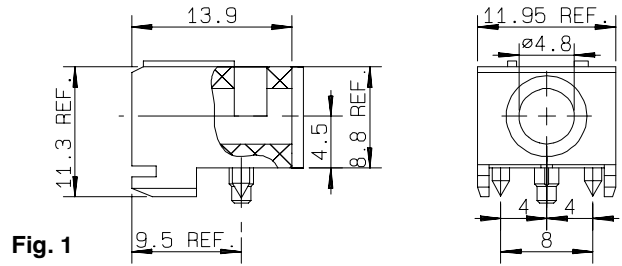

Fig. 1

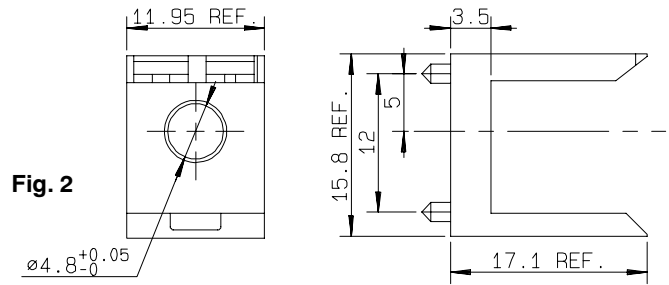

Fig. 2

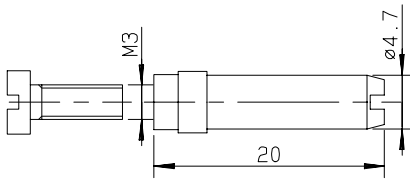

Fig. 3

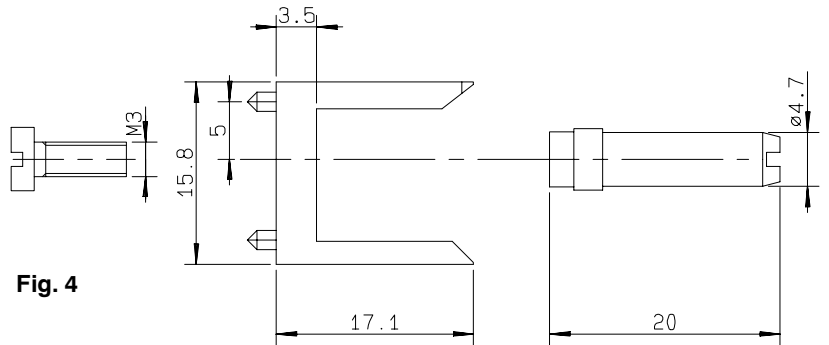

Fig. 4

part number	fig.	designation	P.C.B layout
R280 420 300●	1	Female housing for guide pin	P05
R280 420 310●	2	Male housing for guide pin	P04
R280 420 320●	3	Kit = Guide pin(1) + screw	
R280 420 200●	4	Kit = Male housing + guide pin + screw	P04

(1) Other guide pin length available upon request. Please consult.

● Upon request.

CRIMPING TOOLS



Fig. 1

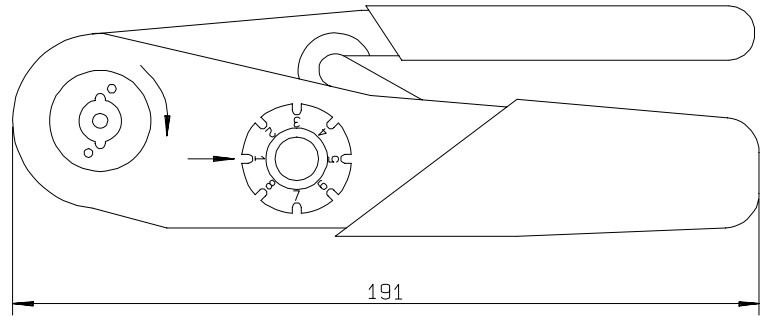

Fig. 2

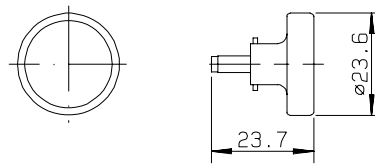
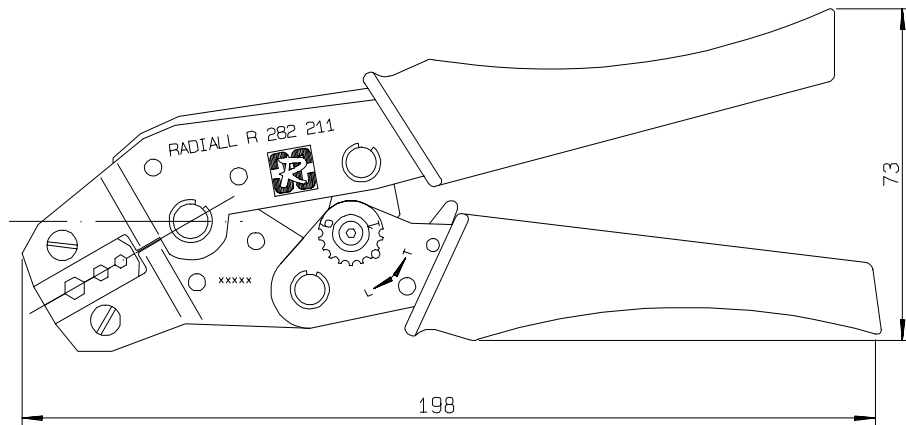
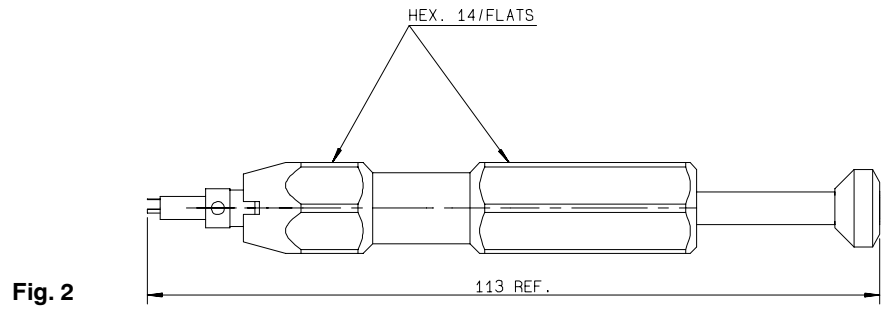
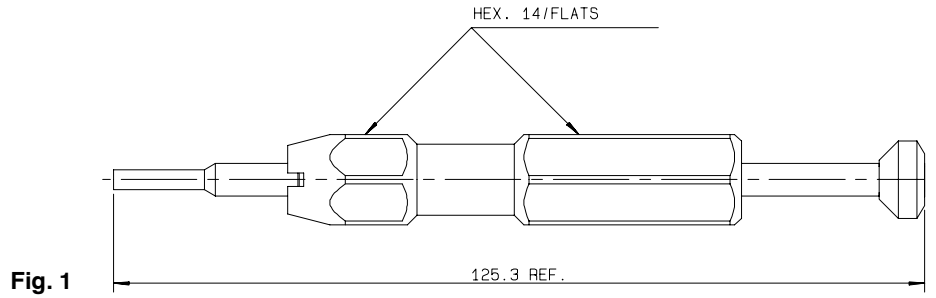

Fig. 3



part number	fig.	designation	notes
R282 281 000	1	Crimping tool	For center contacts
R282 967 030	2	Positionner	
R282 211 000	3	Crimping tool + dies	For ferrules
R282 293 000	N.S.	MIL STD crimping tool (M22520/5.01)	Dies not included
R282 235 003	N.S.	MIL STD - dies (M22520/5.03)	For ferrules

EXTRACTION TOOLS



part number	fig.	use	notes
R282 920 010	1	U01	For male COAXIPACK 2 inserts
R282 920 100	2	U02	For female COAXIPACK 2 inserts

MOUNTING TOOLS FOR PRESS-IN INSERTS AND HOUSINGS

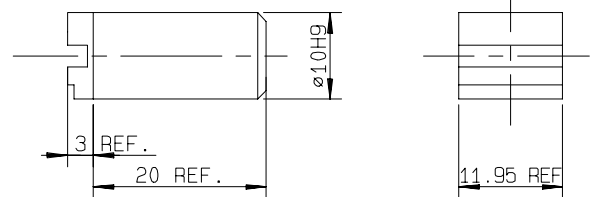
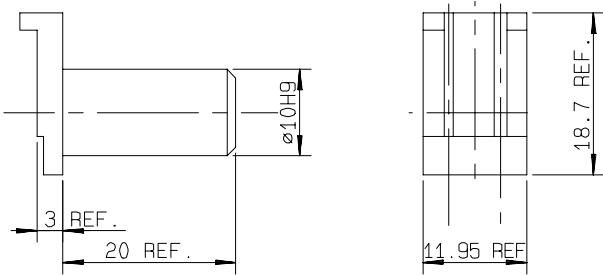

part number	fig.	notes
R282 878 070●	1	Upper tool for press-in housings with fixing stud
R282 878 080●	2	Lower tool for press-in housings with fixing stud

● Upon request.

P 01

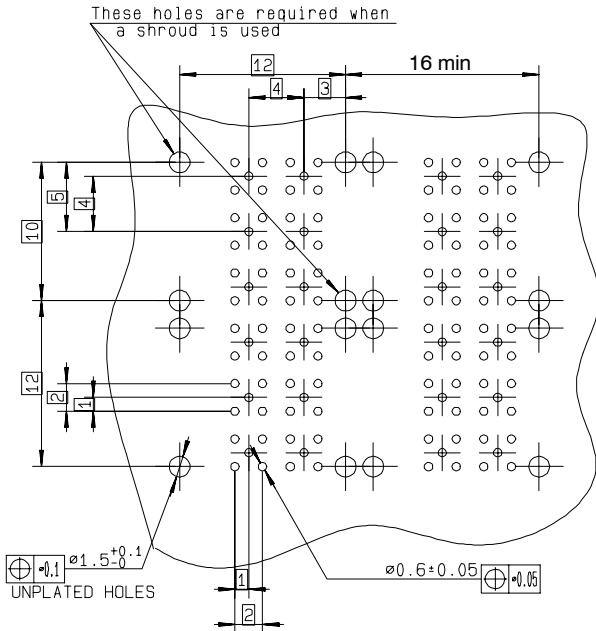

P 02

PART NUMBER	ØDRILLING
R199 001 703	$\varnothing 2.65^{+0.05}_{-0}$
R199 001 713	$\varnothing 2.8^{+0}_{-0.1}$
R199 001 733	$\varnothing 2.8^{+0}_{-0.1}$

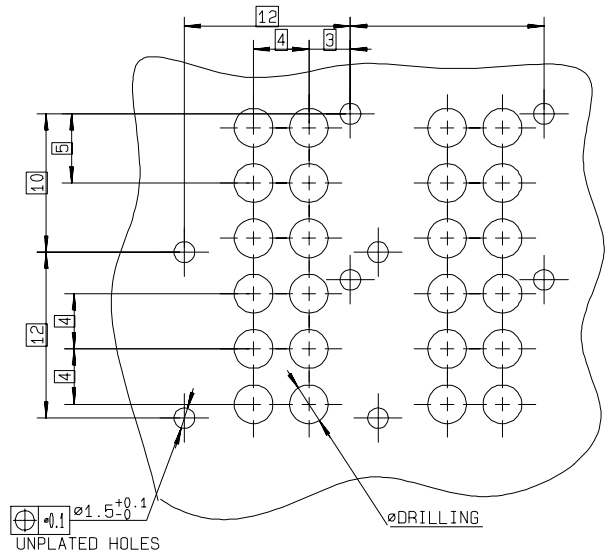

P 03

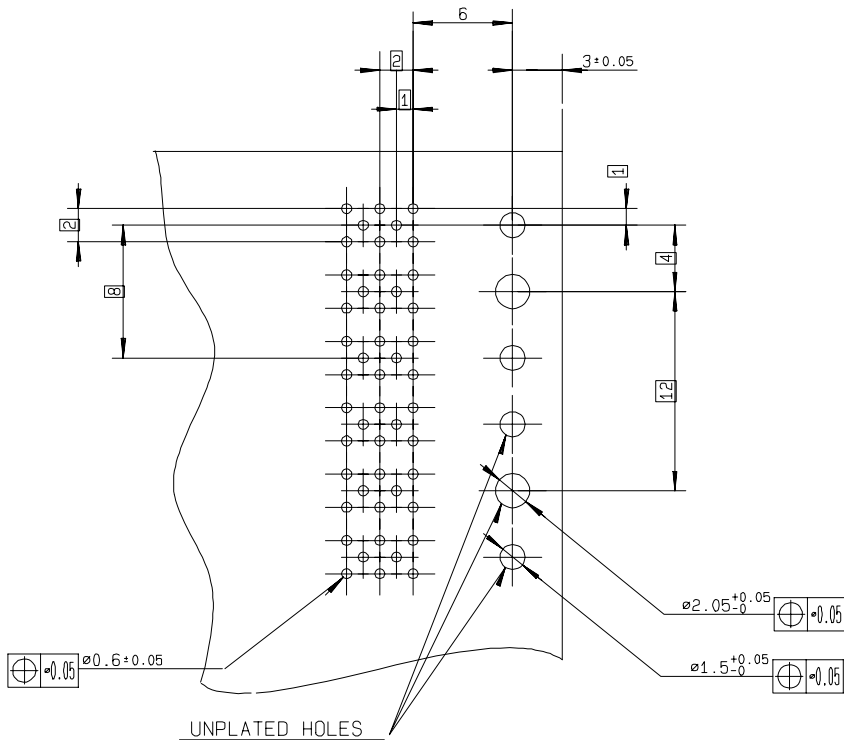

P 04

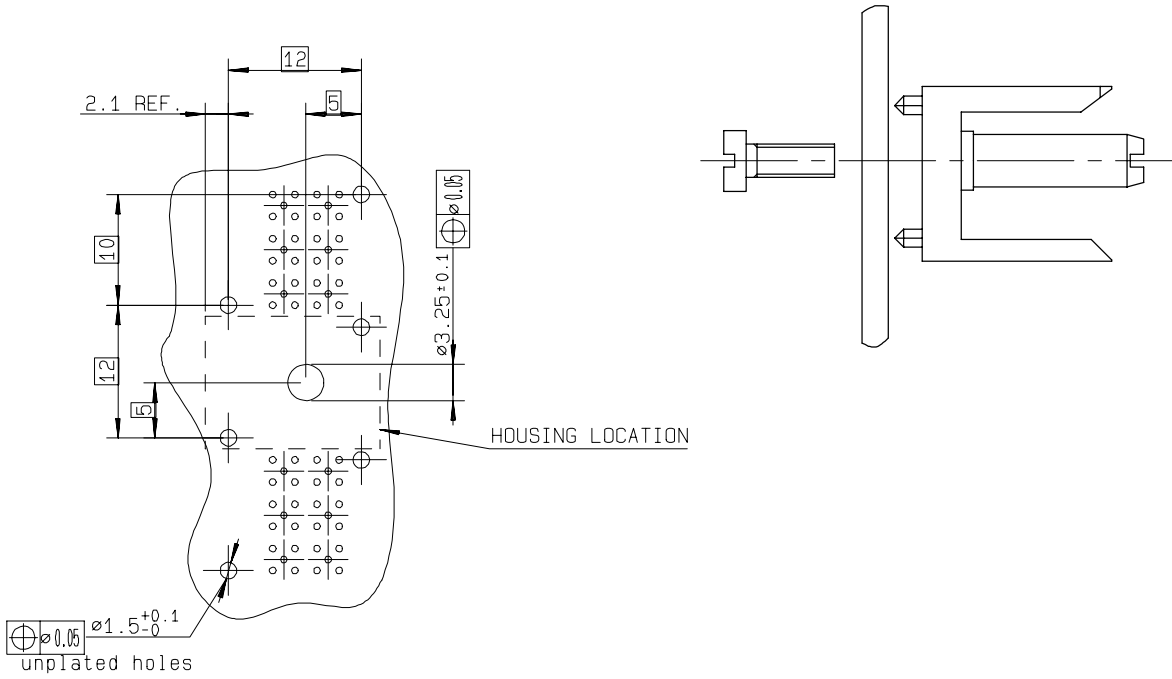

P 05

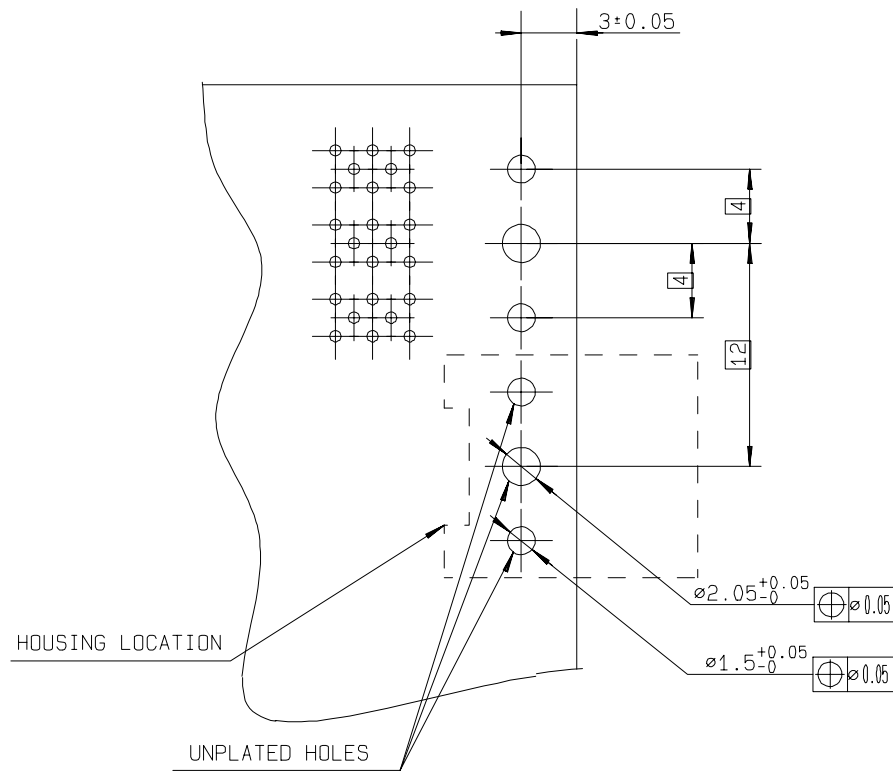

CABLE CONNECTORS

P/N	Mounting	CENTER CONTACT		FERRULE			Assembling procedure	Extraction procedure before soldering	Extraction tool	
		Standard crimping tool + positionner	MIL standard + dies	HEX. (mm)	Standard crimping tool	MIL standard + dies				
R199 001 003	M01	R282 281 000 + Positionner R282 967 030	R282 293 000 + Dies R282 967 030	2,67	R282 211 000	R282 293 000 + Dies R282 235 003		U02	R282 920 100	
R199 001 023 R199 001 053				3,25						
R199 001 203				2,67				U01	R282 920 010	
R199 001 223				3,25						
R694 252 507				2,67				A03	U02	R282 920 100
R694 252 537				3,25						
R694 252 557										

OTHER CONNECTORS

P/N	P.C.B. layout	Assembling	Extraction before soldering	Extraction tool
R199 001 402	P03		U01	R282 920 010
R199 001 452	P03		U01	R282 920 010
R199 001 502	P03		No tool	
R199 001 703	P02			
R199 001 713	P02			
R199 001 733	P02		U01	R282 920 010
R199 002 413	P01			

R280 420 200	P04			
R280 420 300	P05			
R280 420 310	P04			
R285 930 005			U02	R282 920 100

R694 251 021	P01			
R694 251 022	P01			
R694 251 023	P01			
R694 251 024	P01			
R694 251 025	P01			
R694 251 026	P01			
R694 251 027	P01			

P/N	P.C.B. layout	Assembling	Extraction before soldering	Extraction tool
R694 251 111	P03	A02	U01	R282 920 010
R694 251 112	P03	A02	U01	R282 920 010
R694 251 113	P03	A02	U01	R282 920 010
R694 251 114	P03	A02	U01	R282 920 010
R694 251 115	P03	A02	U01	R282 920 010
R694 251 116	P03	A02	U01	R282 920 010
R694 251 117	P03	A02	U01	R282 920 010
R694 251 127	P03	A02	U01	R282 920 010
R694 251 137	P03	A02		
R694 252 101	P03	A01	No tool	
R694 252 102	P03	A01	No tool	
R694 252 103	P03	A01	No tool	
R694 252 104	P03	A01	No tool	
R694 252 105	P03	A01	No tool	
R694 252 106	P03	A01	No tool	
R694 252 107	P03	A01	No tool	
R694 261 035	P03			
R694 261 036	P03			
R694 261 076	P01			
R694 261 906	P02			

A 01 RECOMMENDED PROCEDURE

1

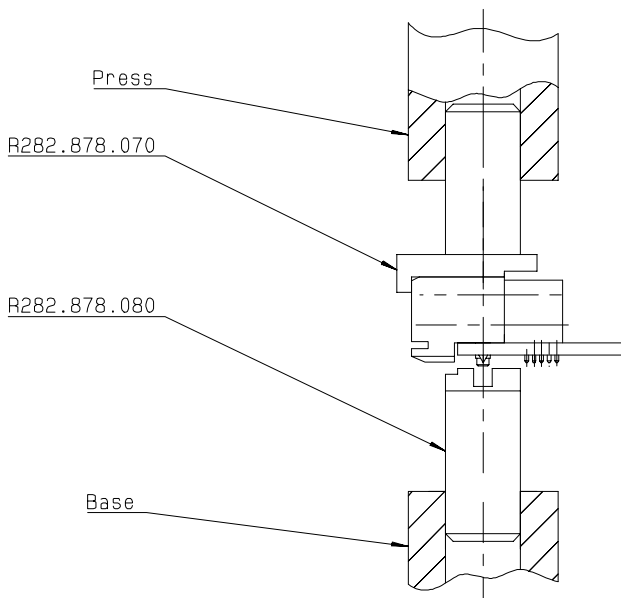

Connectors

R694 252 101	R694 252 105
R694 252 102	R694 252 106
R694 252 103	R694 252 107
R694 252 104	R694 262 036 + inserts R199 001 502

- 1.1 Place the COAXIPACK on the PCB.
- 1.2 Correctly place the PCB between the upper tool R282 878 070 and the lower tool R282 878 080.
- 1.3 Push on the COAXIPACK with the upper tool until the fixing stud is completely inserted in the PCB.

A 02 RECOMMENDED PROCEDURE

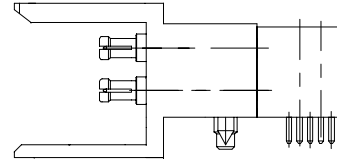

1

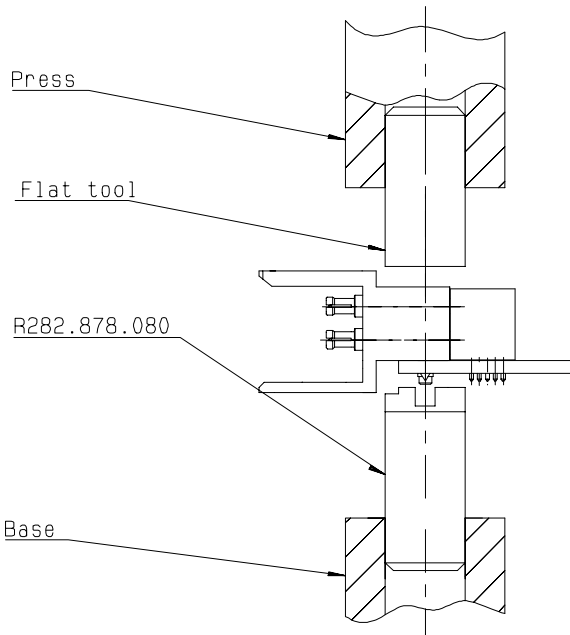

Connectors

R694 251 111	R694 251 116
R694 251 112	R694 251 117
R694 251 113	R694 251 127
R694 251 114	R694 251 137
R694 251 115	R694 261 036 + inserts R199 001 402

- 1.1 Place the COAXIPACK on the PCB.
- 1.2 Correctly place the PCB on the lower tool R282 878 080
- 1.3 Push on the COAXIPACK with the upper flat tool until the fixing stud is completely inserted in the PCB.

A 03 RECOMMENDED PROCEDURE

1

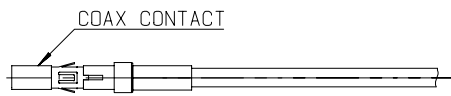

2

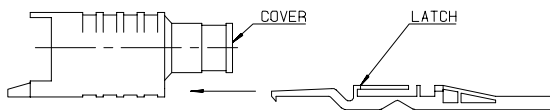

3

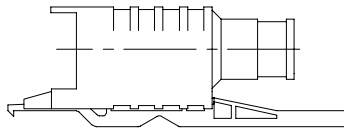

4

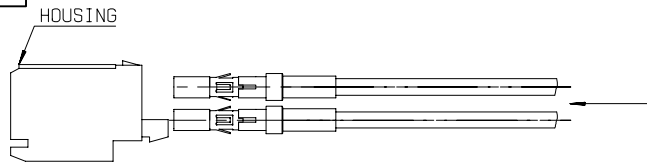

5

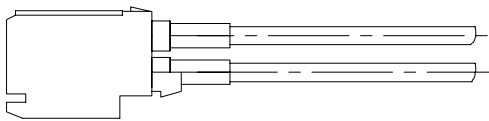

6

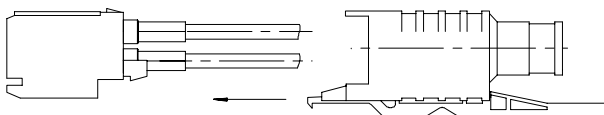

7

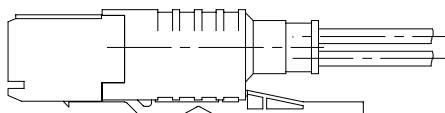

Connectors

R694 252 507
R694 252 537
R694 252 557

1 Mount the coax contact on the cable according to M01 procedure.

2 Slide the latch on the cover.

3 Click on the latch in final position.

4 Present the cable assembly face to housing cavity.

5 Push the cable assembly in bottoms until it click-on.

6 Slide the cover along the cable.

7 Push the cover on the housing until it click-on.

M 01 RECOMMENDED PROCEDURE

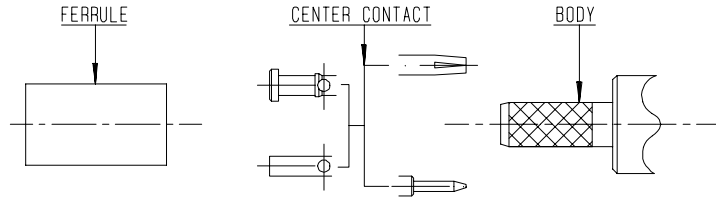

	Stripping	a	b	c	e	Hex. G
a)	Inch	0.098	0.236	0.394	0.295	
	mm	2.5	6	10	7.5	2.67
b)	Inch	0.098	0.197	0.413	0.315	
	mm	2.5	5	10.5	8	3.25
c)	Inch	0.098	0.236	0.433	0.335	
	mm	2.5	6	11	8.5	2.67
d)	Inch	0.098	0.236	0.433	0.335	
	mm	2.5	6	11	8.5	3.25

Connectors			
a)	R199 001 003	c)	R199 001 203
b)	R199 001 023 R199 001 053	d)	R199 001 223

1

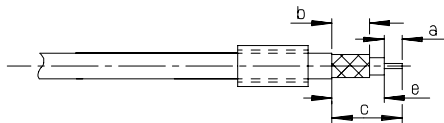

- 1.1 Slide the ferrule onto the cable.
- 1.2 Strip the cable.

2

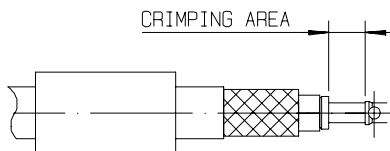

- 2.1 Slide the center contact until it bottoms against the cable dielectric.
- 2.2 Crimp the center contact with crimping tool R282 281 000 (position 4 or position 3 for 2 / 75 Ω cable) + positioner R282 967 030 or crimping tool R282 293 000 (M22520/2-01) + Positioner R282 967 030 (M22520/5-03).

3

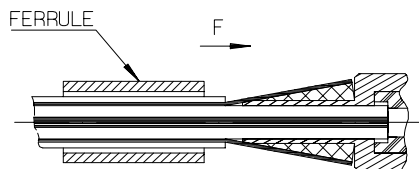

- 3.1 Fan the braid.
- 3.2 Slide the cable into the body until it bottoms against the insulator.
- 3.3 Slide the ferrule over the braid (In direction F).

4

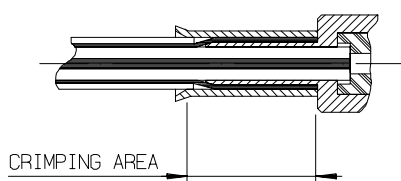

- 4.1 Crimp the ferrule with crimping tool R282 211 000 (Hex.: G) or crimping tool R282 293 000 (M22520 / 5-01) + dies R282 235 003 (M22520 / 5-03).
- 4.2 Cut the excess of braid.

U 01

HOW TO USE TOOL R282 920 010

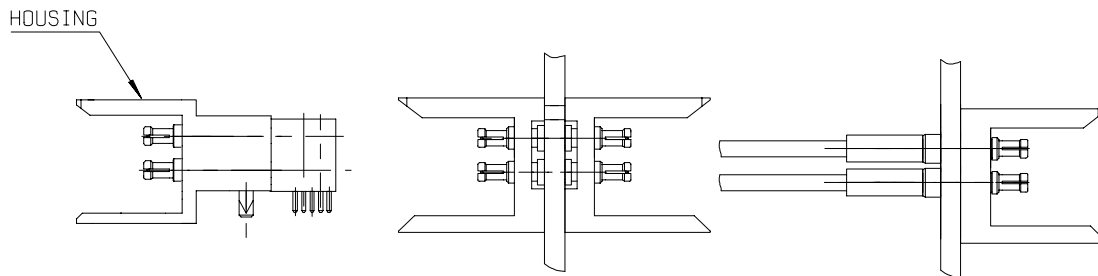

1

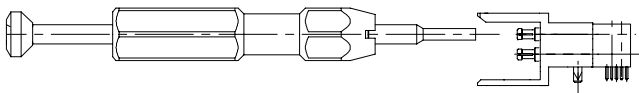

2

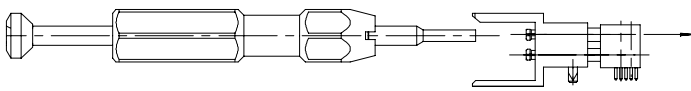

Inserts

R199 001 402
R199 001 733
R199 001 203
R199 001 223
R199 001 452

Pre-assembled modules

R694 251 111
R694 251 112
R694 251 113
R694 251 114
R694 251 115
R694 251 116
R694 251 117
R694 251 127

1.1 Place the extraction tool as shown (upper coaxial contact only for twin coax.) and push in axial direction into the housing until it stops.

2.1 Then press gently on the rod to remove the contact from the rear of the housing.

U 02 HOW TO USE TOOL R282 920 100

1

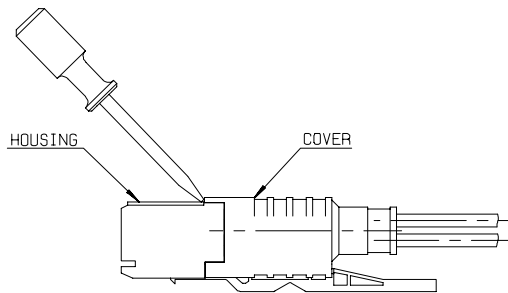

2

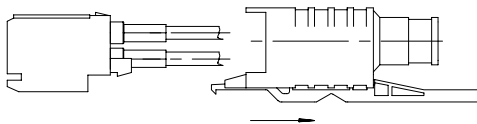

3

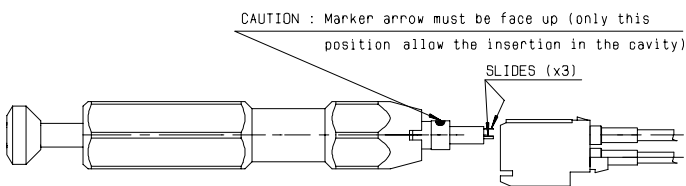

4

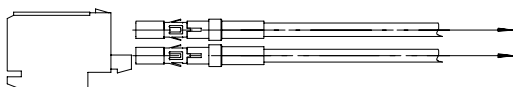

Kits

R285 930 005
R694 252 507
R694 252 537
R694 252 557

Inserts

R199 001 003
R199 001 023
R199 001 053

1.1 Use a screw-driver to remove the cover from the housing as shown.

2.1 Slide the cover along the cable.

3.1 Place the extraction tool (as shown) and push in axial direction into the housing until it stops.

4.1 Then press gently on the piston to remove the contact from the rear of the housing.

COAXIPACK 2

DIMENSIONS OF APPLICABLE CABLES

CABLE DIMENSION REFERENCE CHART

The following tables are presented as a convenient reference only. For detailed specifications, refer to the relevant standard or cable manufacturer's specifications. All dimensions are nominal unless otherwise specified.

CABLE	IMP NOM. Ω	DIMENSIONS inch (mm)					CABLE GROUPE inch (mm)/ Ω
		CORE		DIELECTRIC	SCREEN DIA. + numb.	JACKET	
		Composition	DIA nom.				

FLEXIBLE CABLES MIL-C-17-F

RG 174A/U	50	7 X 0.16	.019 (0.48)	.060 (1.52)	.088 (2.24) (S)	.110 (2.79)	.102 (2.6)/50 S
RG 178B/U	50	7 X 0.10	.012 (0.30)	.033 (0.84)	.054 (1.37) (S)	.071 (1.80)	.079 (2)/50 S
RG 188A/U	50	7 X 0.18	.020 (0.51)	.060 (1.52)	.081 (2.06) (S)	.110 (2.79)	.102 (2.6)/50 S

FLEXIBLE CABLES NF-C 93-550

KX 3B	50	7 X 0.16	.019 (0.48)	.059 (1.50)	.088 (2.23) (S)	.10 (2.54)	.102 (2.6)/50 S
KX 21A	50	7 X 0.10	.012 (0.30)	.034 (0.87)	.054 (1.37) (S)	.071 (1.80)	.079 (2)/50 S
KX 22A	50	7 X 0.18	.020 (0.51)	.059 (1.50)	.081 (2.06) (S)	.098 (2.50)	.102 (2.6)/50 S

FLEXIBLE CABLE

SHF 179/1*	75	solid				.104 (2.65)	.098 (2.5)/75/D
------------	----	-------	--	--	--	-------------	-----------------

* Compatible with connectors for cable 2 mm / 75 Ω only.

INDEX OF P/N

RADIALL P/N	Description	Page
R199 001 003	Straight female inserts full crimp type for 2/50/S cable	21
R199 001 023	Straight female inserts full crimp type for 2.6/50/S cable	21
R199 001 053	75 Ω Straight female insert full crimp type for 2.5/75/D cable	29
R199 001 203	Straight male inserts full crimp type for 2/50/S cable	23
R199 001 223	Straight male inserts full crimp type for 2.6/50/S cable	23
R199 001 402	Right angle male solder type PCB insert	16
R199 001 452	75 Ω Right angle male solder type PCB insert	27
R199 001 502	Right angle female solder type PCB insert	18
R199 001 703	Male male non removable insert for panel thickness 2 mm	25
R199 001 713	Male male non removable insert for panel thickness 2.4 mm	25
R199 001 733	Male male removable insert for panel thickness 3.2 mm	24
R199 002 413	Straight male solder type PCB insert	14
R199 031 003	Straight female insert full crimp type for 2/50/S cable (specific)	22
R199 031 023	Straight female insert full crimp type insert for 2.6/50/S cable (specific)	22
R280 420 010	Cover	20-28
R280 420 030	Latch	20-29
R280 420 058	Kit = female housing + cover + latch	20
R280 420 070	Male coding part	9
R280 420 080	Female coding part	9
R280 420 200	Kit = male housing + guide pin + screw	30
R280 420 300	Female housing for guide pin	30
R280 420 310	Male housing for guide pin	30
R280 420 320	Kit = guide pin + screw	30
R280 741 010	Qualification kit	26

RADIALL P/N	Description	Page
R282 211 000	Crimping tool + dies for ferrules	31
R282 235 003	MIL Standard dies for ferrules	31
R282 281 000	Crimping tool for center contacts	31
R282 293 000	MIL Standard crimping tool	31
R282 878 070	Upper mounting tool for press-in housings with fixing stud	32
R282 878 080	Lower mounting tool for press-in housings with fixing stud	32
R282 920 010	Extraction tool for male COAXIPACK 2 inserts	32
R282 920 100	Extraction tool for female COAXIPACK 2 inserts	32
R282 967 030	Positionner	31
R284 906 002	Demonstration pigtail 20cm length	26
R285 930 005	Standard cable assembly with 2.6/50/S cable (100 cm)	26
R299 400 020	Mother demonstration board	26
R299 400 030	Daughter demonstration board	26
R694 251 021	Straight male module (with 2 PCB male coaxial inserts)	14
R694 251 022	Straight male module (with 2 PCB male coaxial inserts)	14
R694 251 023	Straight male module (with 2 PCB male coaxial inserts)	14
R694 251 024	Straight male module (with 4 PCB male coaxial inserts)	14
R694 251 025	Straight male module (with 4 PCB male coaxial inserts)	14
R694 251 026	Straight male module (with 4 PCB male coaxial inserts)	14
R694 251 027	Straight male module (with 6 PCB male coaxial inserts)	14
R694 251 111	Right angle male module (with 2 PCB male coaxial inserts)	15
R694 251 112	Right angle male module (with 2 PCB male coaxial inserts)	15
R694 251 113	Right angle male module (with 2 PCB male coaxial inserts)	15
R694 251 114	Right angle male module (with 4 PCB male coaxial inserts)	15
R694 251 115	Right angle male module (with 4 PCB male coaxial inserts)	15
R694 251 116	Right angle male module (with 4 PCB male coaxial inserts)	15
R694 251 117	Right angle male module (with 6 PCB male coaxial inserts)	15
R694 251 127	Right angle male module (with 6 PCB male coaxial inserts) (shielded)	15
R694 251 137	75 Ω Right angle male module (with 6 PCB male coaxial inserts) (shielded)	27
R694 252 101	Right angle female module (with 2 PCB female coaxial inserts)	17
R694 252 102	Right angle female module (with 2 PCB female coaxial inserts)	17
R694 252 103	Right angle female module (with 2 PCB female coaxial inserts)	17
R694 252 104	Right angle female module (with 4 PCB female coaxial inserts)	17
R694 252 105	Right angle female module (with 4 PCB female coaxial inserts)	17
R694 252 106	Right angle female module (with 4 PCB female coaxial inserts)	17
R694 252 107	Right angle female module (with 6 PCB female coaxial inserts)	17
R694 252 507	Straight female kit for 2/50/S cable assemblies	19
R694 252 537	Straight female kit for 2.6/50/S cable assemblies	19
R694 252 557	75 Ω Straight female kit (shielded) for 2.5/75/D cable	28
R694 261 035	Male housing with press-in fixing stud (shielded)	16-27
R694 261 036	Male housing with press-in fixing stud	16-27
R694 261 076	Male housing (for non removable inserts)	14-25
R694 261 906	Male housing (for removable inserts)	23-24
R694 262 036	Female housing with press-in fixing stud (for right-angle inserts)	18
R694 262 056	Female housing for removable cable inserts	20-28
R694 262 906	Female housing with press-in fixing stud (for straight inserts)	21
R694 352 507	Straight female kit for cable assemblies (specific)	22
R694 352 537	Straight female kit for cable assemblies (specific)	22